

INSUL-8 CORPORATION

HEVI-BAR INSTALLATION INSTRUCTIONS

NO. 875030

GENERAL

Before starting the installation of a Hevi-Bar™ system, read these instructions all the way through. You will notice the term "SLIDING TIGHT" used several times. This is VERY IMPORTANT, and means that the hanger clamps must support the bar firmly while still allowing it to SLIDE back and forth as the temperature changes.

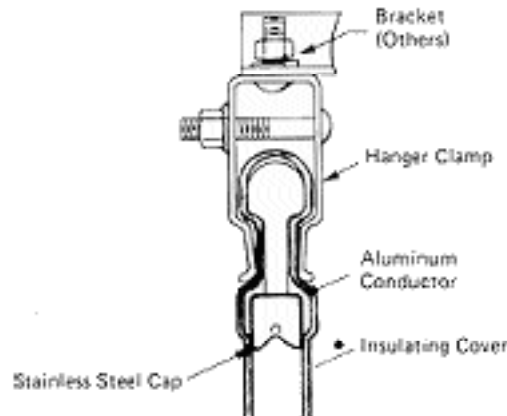

With a hanger clamp in "sliding tight" position the conductor bar can be moved up and down approximately 1/8".

All conductor bar support hanger clamps must be sliding tight except at ANCHOR POINTS.

ANCHOR POINTS

(A) If there are no expansion joints in the system, tighten one hanger clamp per conductor at a point in the center of the run. This is called an ANCHOR POINT.

(B) If expansion sections are used the conductor must be anchored approximately half way between each expansion section and half way between the last expansion section and the end of the runway.

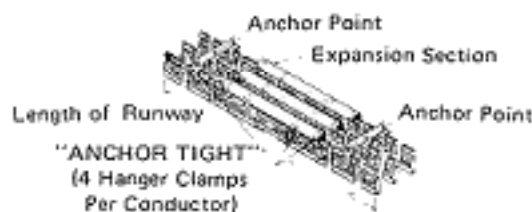

Note: There are NEVER any anchor points on an expansion section.

EXPANSION SECTION APPLICATIONS

1. Must be used at all structural expansion joints.
2. Use as required by system thermal expansion, based on the standard design conditions of 110°F (60°C) maximum temperature change:

For example, in the sketch the distance between anchor points is not to exceed 240'. Longer runs or severe ambient conditions will require additional expansion sections. Consult factory.

ANCHOR POINT LOCATIONS

1. Systems without expansion sections: anchor tight at center of run only; all others must be sliding tight.
2. Systems with one expansion section see layout.
3. Systems with more than one expansion section:
 - a. Anchor point to be midway of each expansion section.
 - b. Anchor point also midway of last expansion section and end of runway.
4. Anchor Point: Standard hanger clamp with cross bolts tightened so clamp is rigid with conductor.

TYPICAL HEVI-BAR 3 PHASE RUNWAY

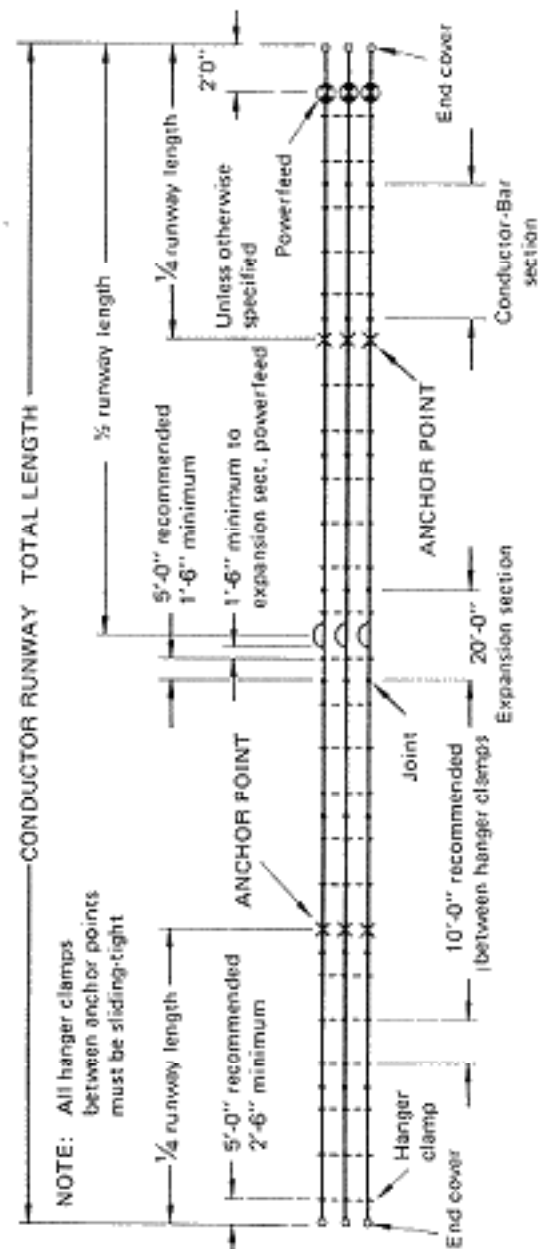

NOTE: All hanger clamps between anchor points must be sliding-tight

STEP 1

Mount All Hanger Clamps.

Attach hanger clamp to hanger bracket and tighten down hanger nut. Make sure hanger clamp is parallel to the run of bar and not cocked in ANY direction.

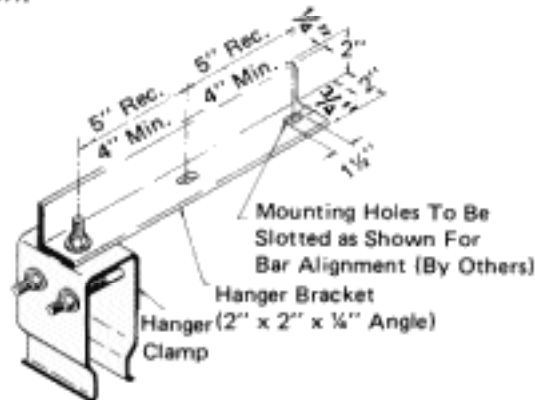

Note:

Bottom surface of hanger bracket angle iron must be parallel to the horizontal plane of the conductor run.

STEP 2

Install Expansion Sections.

(On short runs where no expansion sections are used, proceed directly to Step 3.)

(A) Determine the location of expansion section from construction drawing. Install this section in desired location. **DO NOT REMOVE THE SHIPPING SUPPORT UNTIL THE SECTION HAS BEEN HUNG IN PLACE.** Be careful not to twist or bend this section while handling. Cut the steel strapping and discard the support. If not already connected, install the jumper cable or cables in the powerfeed lug. **MAKE THIS CONNECTION TIGHT!**

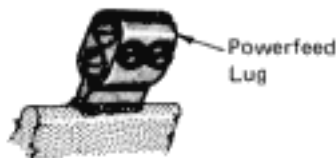

(B) Set expansion gap as follows:

If the average daytime temperature during the installation period for the entire job is running:

- Hot (over 100° F) leave 7½" gap
- Medium (60° F) leave 9" gap
- Cold (20° F) leave 10½" gap

Tighten all cross bolts on all four hanger clamps attached to alignment bracket. **THE CROSS BOLTS ON ONE SIDE OF THE GAP MUST BE LOOSENED LATER.** (SEE STEP 6.) Continue to Step 3 for standard conductor lengths.

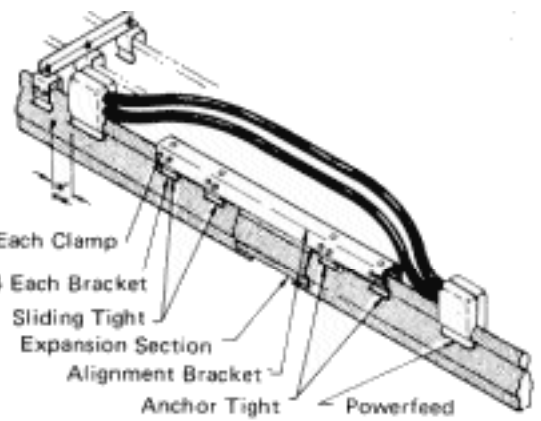

STEP 3

Install Standard Sections.

Leaving cross bolts loose, snap sections in place.

Make sure that the hanger clamps are still parallel to the run of bar and not cocked in any direction.

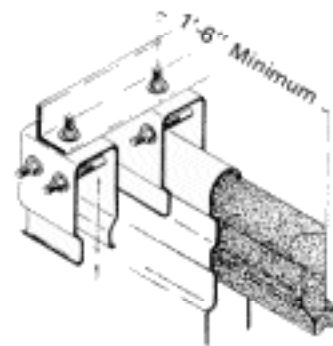

STEP 4

Install Powerfeed Sections.

Determine the location of the powerfeed sections from the construction drawing.

Leaving cross bolts loose, snap into place in the same manner as standard sections.

Verify that the powerfeed lug is in the desired location with respect to the power source.

Sometimes reversing the bar will make this easier.

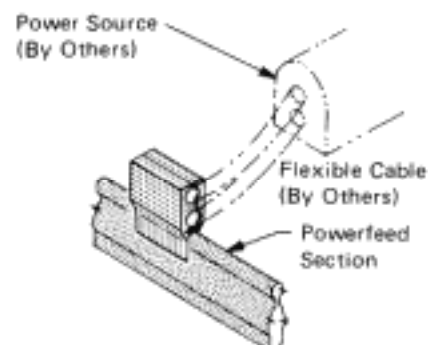

STEP 5

Join Bar

Join Hevi-Bar® lengths (starting with expansion section, if used) by bolting.

BOLTED SPLICES

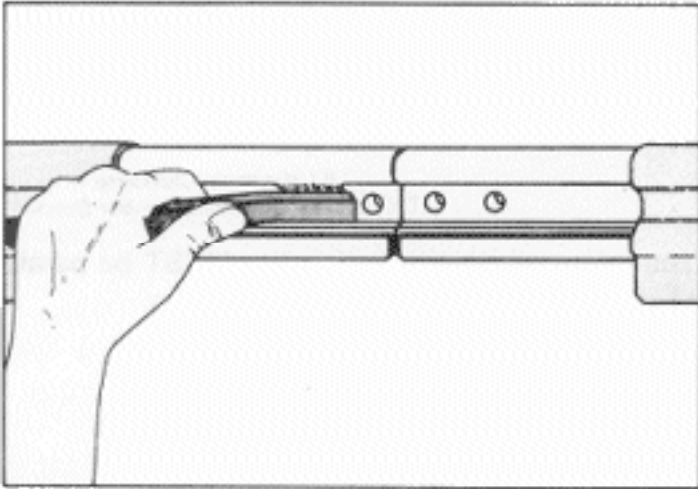

1. Clean the area to be joined on the conductor and splice plate. This can be done with a clean wire brush or an emery cloth.

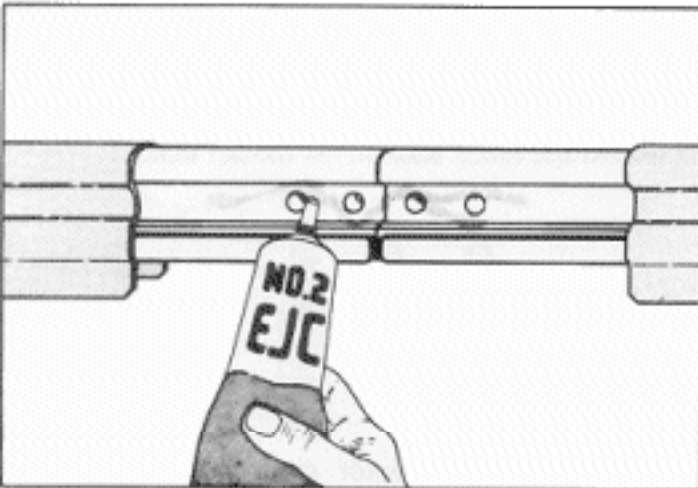

2. Immediately spread with conservative quantity of EJC-2 compound over the cleaned surfaces. (1-8 oz. tube for 10 joints).

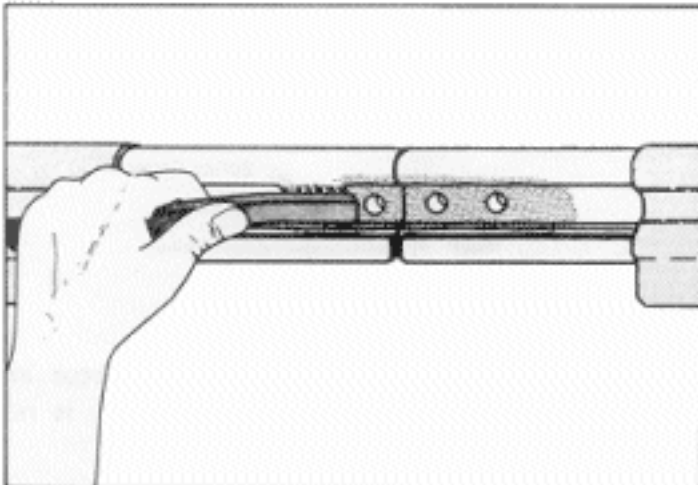

3. Rub the compound well into the surface with the emery cloth or wire brush.

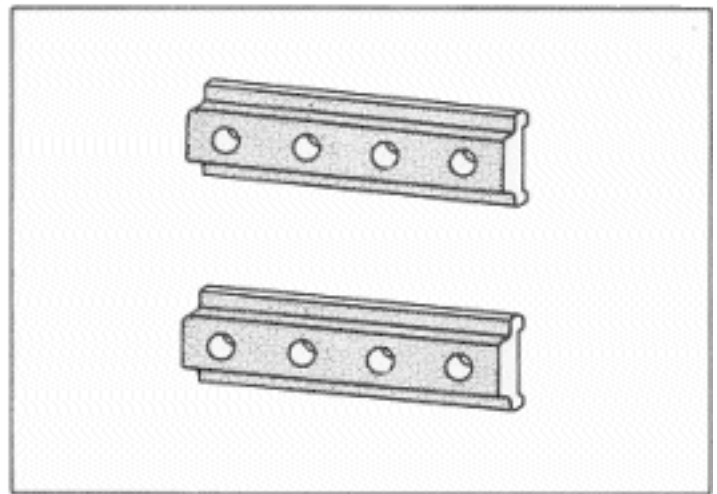

4. Repeat steps 1-3 on other side of conductor and the contact side of both splice plates.

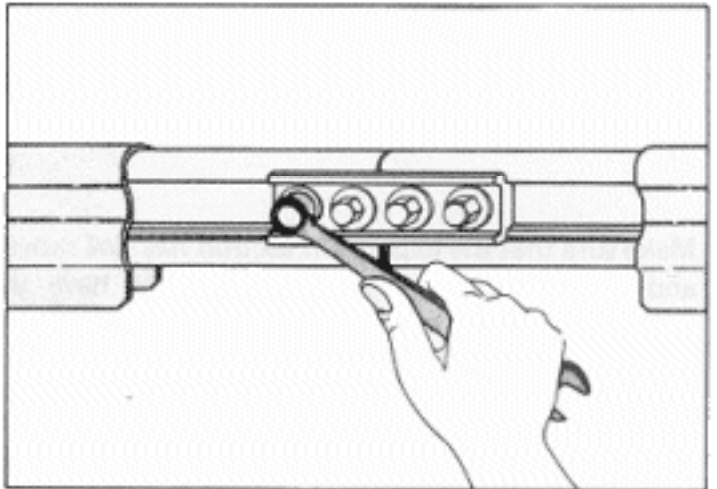

5. Place the splice plate in position and bolt down tightly. Each bolt in a 500 amp joint requires 12 ft. lb. of torque while the 1000 and 1500 amp sizes require 20 ft. lbs. per bolt.

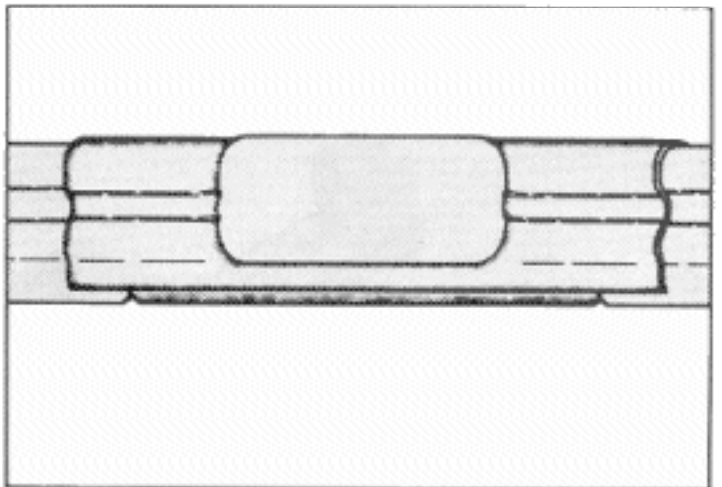

6. Finish the splice by snapping on the splice cover.

CAUTION: Keep work clean. Do not prepare splice plates until time to use.

STEP 6

Final Check of Expansion Sections.

(If no expansion sections are used, proceed to Step 7.)

After the entire run has been joined together, loosen four bolts on the alignment clamp on the SAME SIDE of the expansion gap until they are sliding tight.

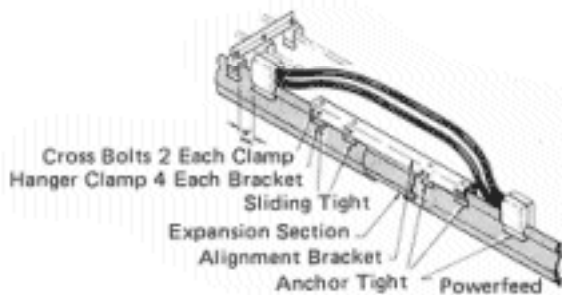

Make sure that the expansion section has not moved and that its supporting hanger clamps have the proper clearances to the jumper lug, 18". Verify that the gap setting is correct for the present temperature.

STEP 7

Connect Powerfeed Sections.

The powerfeed is designed to accept one or two flexible cables, 2/0-750 MCM. Simply flip the movable part over to secure the smaller sizes under 350 MCM. Cables should both be the same size.

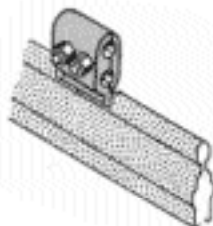

Before installing the powerfeed covers, remove the flashing with a sharp knife. This will adapt the cover to your particular installation. Make certain that the feeder cables do not interfere with movement of the conductor as the system expands or contracts with temperature changes.

INSUL-8 CORPORATION
867 American Street
San Carlos, California 94070
(415) 595-3050
FAX: (415) 595-4801
Order Entry: 1-800-521-4888

INSUL-8 CORPORATION
506 Winthrop
Addison, Illinois 60101

INSUL-8 CORP. (Canada) Ltd.
175 Boulevard J.F. Kennedy
St. Jerome, Quebec J7Y 4B5 Canada
(514) 432-2228
FAX: (514) 432-6985

PRINTED IN U.S.A. (1K89)

COLLECTOR MOUNTING

The mounting bar position (welded or bolted) is most important.

SIDE VIEW

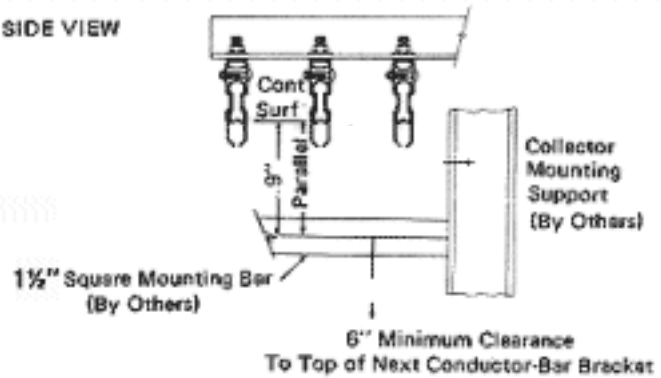

The edges of the mounting bar MUST be parallel to the surface plane of the conductors.

END VIEW

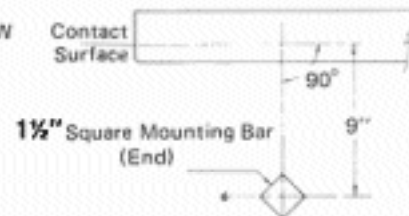

The square steel mounting bar must then be rotated until it is exactly diagonal to the surface plane of the conductors.

Note: Improper positioning of the mounting bar will result in uneven and excess wear on the contact shoes.

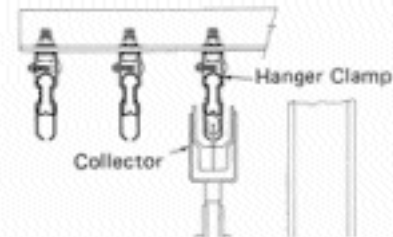

Slide the inner collector onto the mounting bar until it is directly under the inner conductor.

Check vertical alignment and tighten the collector clamp on the mounting bar. Engage collector in the conductor and repeat above for the remaining collectors. Spring pressure on the collectors is factory set between 20 and 35 pounds.

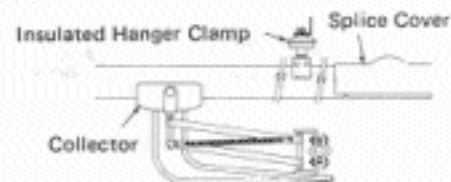

Splice the #3AWG pigtails on the collector into the equipment supply leads. The system is now ready to be tested.