

# CLUSTER BAR

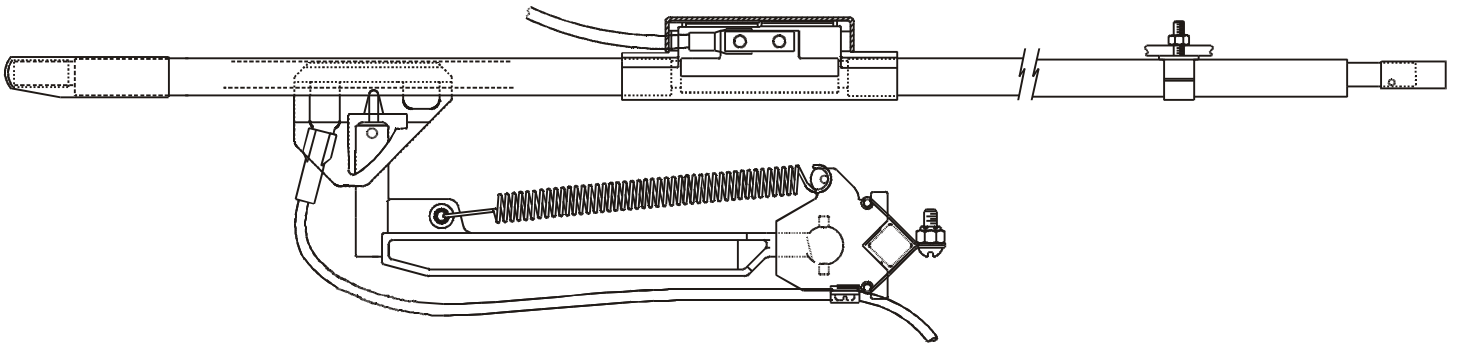

## 1.0 SAFETY

## 2.0 INSTALLATION

## 3.0 MAINTENANCE

## 4.0 TROUBLESHOOTING

## 5.0 TYPICAL INSTALLATIONS



10102 F Street Omaha, NE 68127-1181 • 402/339-9300 • Fax 402/339-9627  
• USA 800/452-0052 800/334-3283 CANADA •

---

## INSUL-8 CORPORATION

The technical data and images which appear in this manual are for informational purposes only. **NO WARRANTIES, EXPRESS OR IMPLIED, INCLUDING WARRANTIES OF MERCHANTABILITY OR FITNESS FOR A PARTICULAR PURPOSE, ARE CREATED BY THE DESCRIPTIONS AND DEPICTIONS OF THE PRODUCTS SHOWN IN THIS MANUAL.** Insul-8 makes no warranty (and assumes no liability) as to function of equipment or operation of systems built according to customer design or of the ability of any of its products to interface, operate or function with any portions of customer systems not provided by Insul-8.

Seller agrees to repair or exchange the goods sold hereunder necessitated by reason of defective workmanship and material discovered and reported to Seller within one year after shipment of such goods to Buyer.

Except where the nature of the defect is such that it is appropriate, in Seller's judgment, to effect repairs on site, Seller's obligation hereunder to remedy defects shall be limited to repairing or replacing (at Seller's option) FOB point of original shipment by Seller, any part returned to Seller at the risk and cost of Buyer. Defective parts replaced by Seller shall become the property of Seller.

Seller shall only be obligated to make such repair or replacement if the goods have been used by Buyer only in service recommended by Seller and altered only as authorized by Seller. Seller is not responsible for defects which arise from improper installation, neglect, or improper use or from normal wear and tear.

Additionally, Seller's obligation shall be limited by the manufacturer's warranty (and is not further warranted by Seller) for all parts procured from others according to published data, specifications or performance information not designed by or for Seller.

Seller further agrees to replace or at Seller's option to provide a refund of the sales price of any goods that do not conform to applicable specifications or which differ from that agreed to be supplied which non-conformity is discovered and forthwith reported to Seller within thirty (30) days after shipment to the Buyer. Seller's obligation to replace or refund the purchase price for non-conforming goods shall arise once Buyer returns such goods FOB point of original shipment by Seller at the risk and cost of Buyer. Goods replaced by Seller shall become the property of Seller.

There is no guarantee or warranty as to anything made or sold by Seller, or any services performed, except as to title and freedom from encumbrances and, except as herein expressly stated and particularly, and without limiting the foregoing, **there is no guarantee or warranty, express or implied, of merchantability or of fitness for any particular purpose or against claim of infringement or the like.**

Seller makes no warranty (and assumes no liability) as to function of equipment or operation of systems built to Buyer's design or of the ability of any goods to interface, operate or function with any portions of Buyer's system not provided by Seller.

Seller's liability on any claim, whether in contract, tort (including negligence), or otherwise, for any loss or damage arising out of, connected with, or resulting from the manufacture, sale, delivery, resale, repair, replacement or use of any products or services shall in no case exceed the price paid for the product or services or any part thereof which give rise to the claim. In no event shall Seller be liable for consequential, special, incidental or other damages, nor shall Seller be liable in respect of personal injury or damage to property not the subject matter hereof unless attributable to gross misconduct of Seller, which shall mean an act or omission by Seller demonstrating reckless disregard of the foreseeable consequences thereof.

Seller is not responsible for incorrect choice of models or where products are used in excess of their rated and recommended capacities and design functions or under abnormal conditions. Seller assumes no liability for loss of time, damage or injuries to property or persons resulting from the use of Seller's products. Buyer shall hold Seller harmless from all liability, claims, suits and expenses in connection with loss or damage resulting from operation of products or utilization of services, respectively, of Seller and shall defend any suit or action which might arise therefrom in Buyer's name - provided that Seller shall have the right to elect to defend any such suit or action for the account of Buyer. The foregoing shall be the exclusive remedies of the Buyer and all persons and entities claiming through the Buyer.

# 1.0 SAFETY

1.1 Disconnect Power and follow all lock-out tag-out procedures as described in Appendix A of OSHA Section 1910.147.

1.2 All personnel must practice strict adherence to both local and national safety procedures, codes, regulations, and ordinances.

1.3 All personnel installing a power rail system should be familiar with the layout details and the component locations.

1.4 **WARNING:** The law recognizes that electrical energy as commonly used in industrial and transit

operations is dangerous and capable of causing serious damage, injury or death. Requirements governing the handling and use of electricity, some general and some very specific and detailed, are found in various statutes like the Workmen's Compensation Acts, Employer's Liability Acts, National Electrical Safety Code (U.S. Dept. of Commerce), Occupational Safety and Health Administration (OSHA), etc. and city or local ordinances. When using electrical power, the law imposes the general obligation to use care to protect against accidental injury or damage to properties.

# 2.0 INSTALLATION

## 2.1 Hanger Clamps

2.1.1 Bolt hanger clamps to support. Be sure hangers are not cocked or twisted. Torque nut 70 in. lbs.

2.1.2 Maximum spacing of hanger clamps:

1' - 6" for curves less than 5' radius
2' - 0" for curves greater than 5' radius
3' - 0" for straights

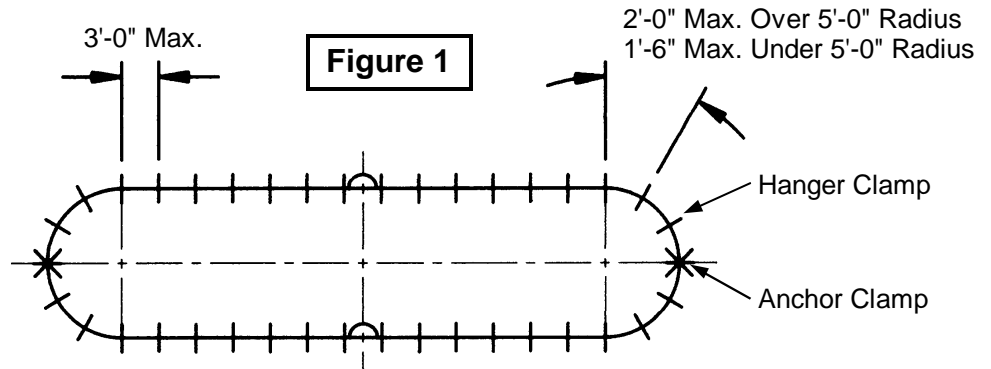

2.1.3 Spacing is identical for lateral or vertical mounts (see Figure 1).

2.1.4 Snap Cluster Bar with cover into hanger clamps making sure that bottom of hanger clamps are completely gripping bottom of conductor bar cover (see Figure 2).

2.1.5 Specifications for various hanger clamps and brackets are shown on the diagram below and on the next page:

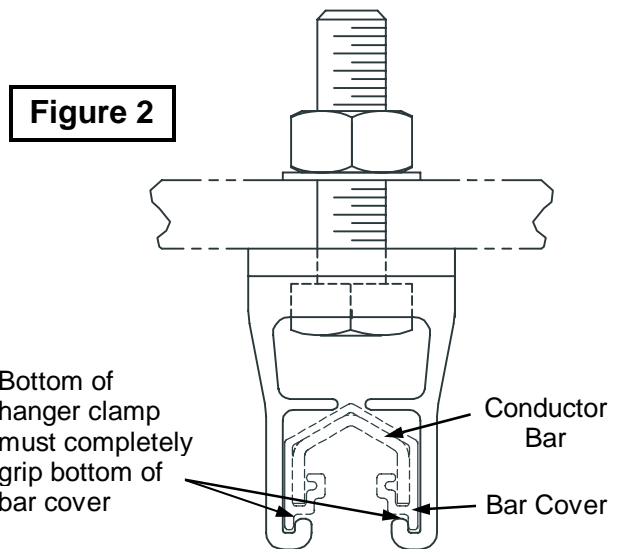
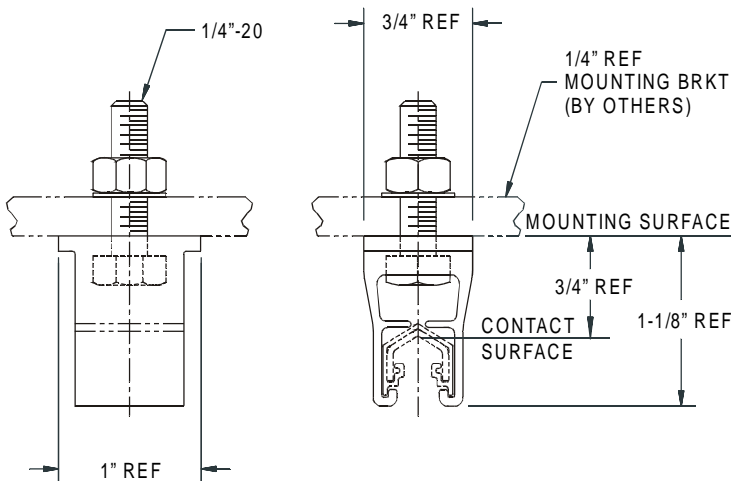

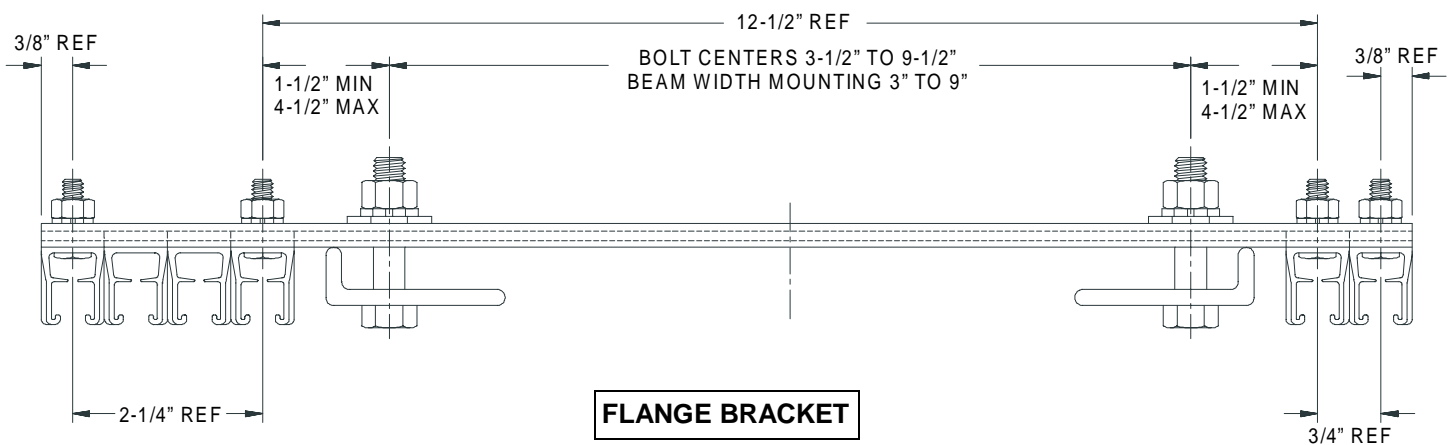
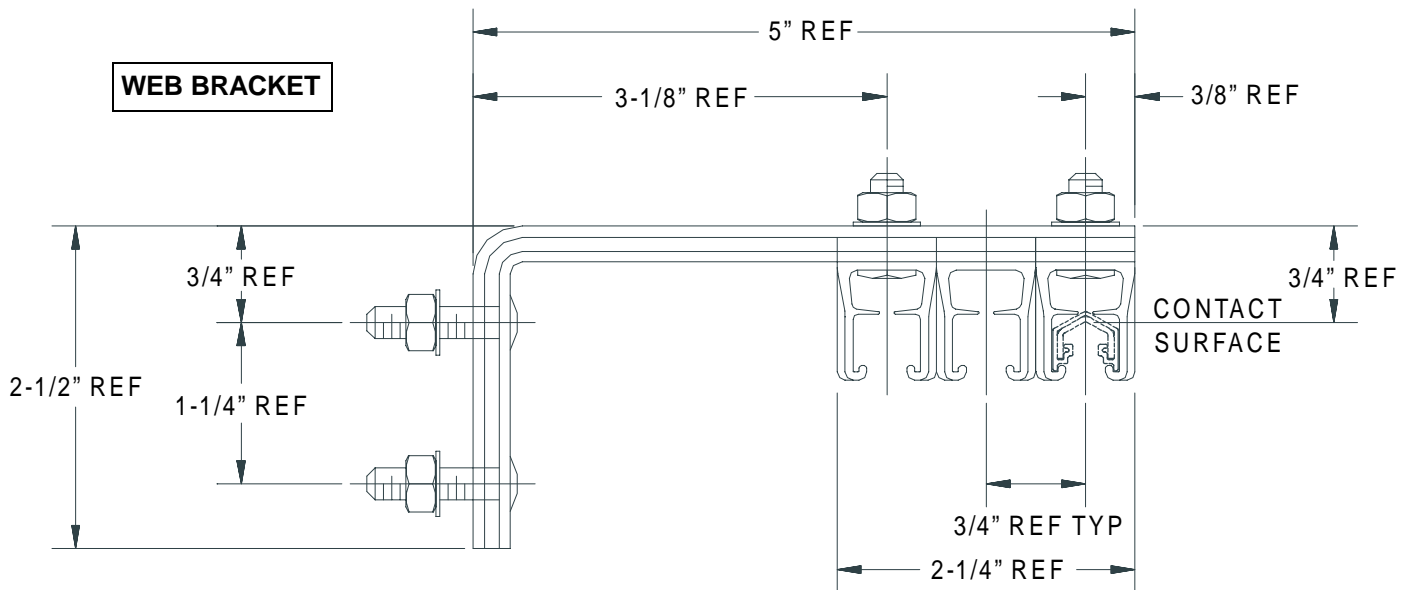
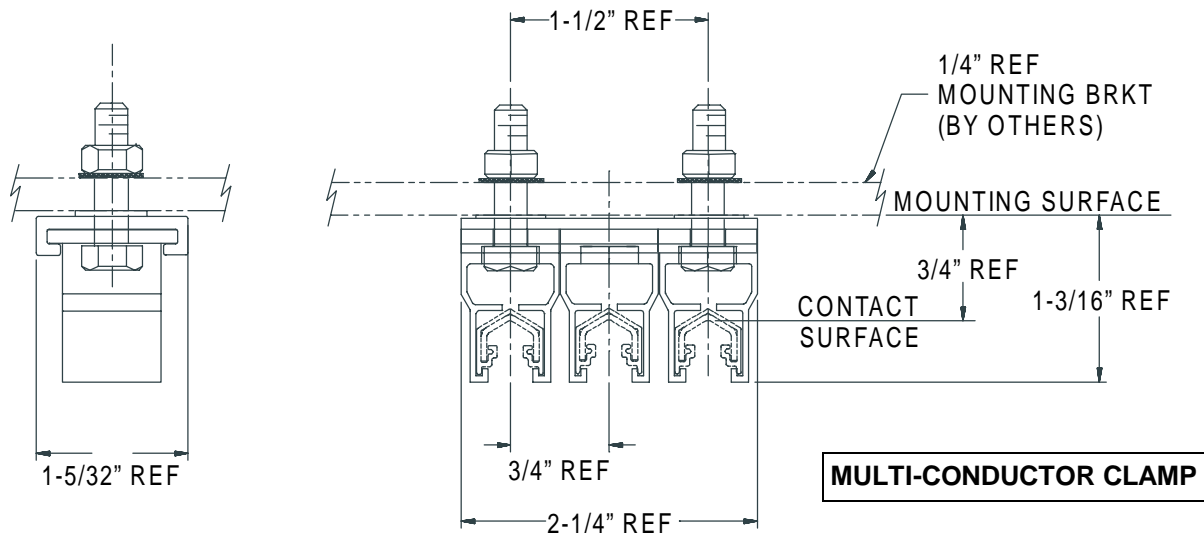

## 2.2 Splices

### 2.2.1 Crimp Splices

2.2.1.1 One end of each 15' length of Cluster Bar has a factory attached crimp joint.

2.2.1.2 To join two conductors, slide the end without a splice into the splice of the next conductor. Butt conductors together before crimping the joint.

2.2.1.3 To secure the splice, crimp the bottom of each side of the splice at 1/4" and again at 3/4" from the end using the "Crimp Tool" (see Figure 3).

2.2.1.4 Snap splice covers together and press retainer cap over top.

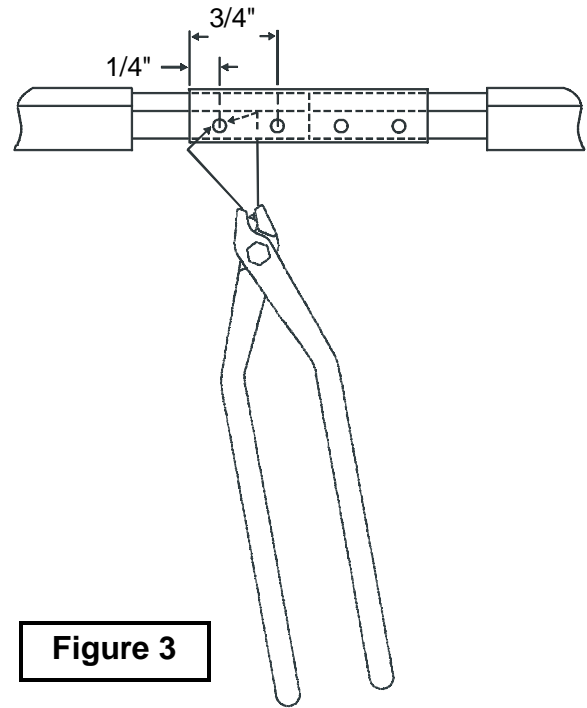

Figure 3

### 2.2.2 Bolted Splices

2.2.2.1 Butt conductor bar together and place bolted splice halves at center of joint and fasten with hardware supplied (see Figure 4).

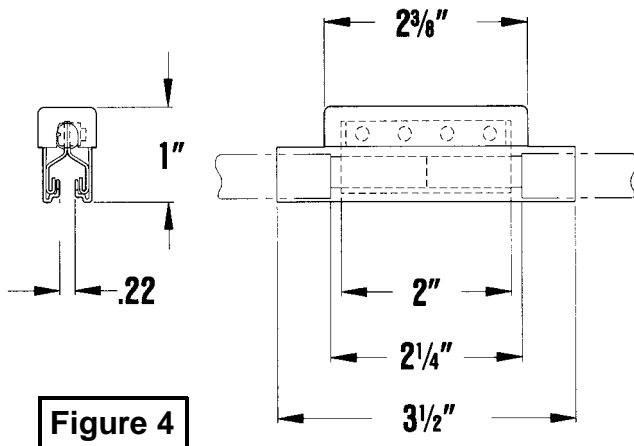

Figure 4

2.2.3 **Note:** Always install curved conductor first.

### 2.2.4 Splice Cover

2.2.4.1 Snap cover halves onto conductor enclosing the splice joint halves. **Note:** The PVC conductor cover extends inside the cover halves so that none of the conductor is exposed. A "cut-out" in the cover halves is provided to allow for this cover.

2.2.4.2 **Important: DO NOT allow the cover halves to overlap the PVC conductor cover. Overlapping the cover may derail the collector during operation (see Figure 5).**

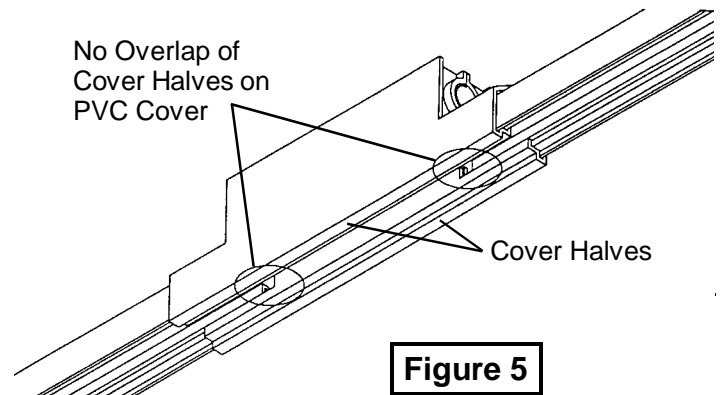

Figure 5

## 2.3 Field Cutting

2.3.1 Square cuts are required for proper joining.

2.3.2 Deburr outside of Cluster Bar to attach splice. Deburr inside of Cluster Bar for smooth surface to guide collector shoe.

2.3.3 To allow for length of splices, cut cover 2 1/4" less than length of bar (1-1/8" from each end).

## 2.4 Powerfeed

2.4.1 Locate powerfeed at a joint or end, or install powerfeed at any point along a straight run by cutting out 2-1/4" of the conductor cover.

### 2.4.2 Joint Powerfeed (See Figures 6 & 7)

2.4.2.2 Attach a wire to terminal supplied with Powerfeed Kit. Place powerfeed halves and terminal on conductor bar and fasten supplied hardware.

2.4.2.3 Snap on powerfeed cover halves and press retainer cap over top.

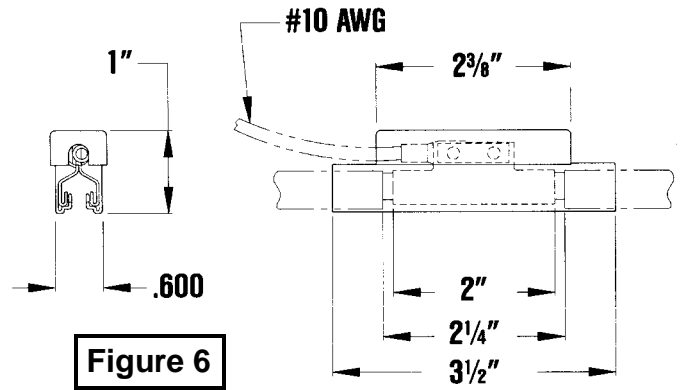

Figure 6

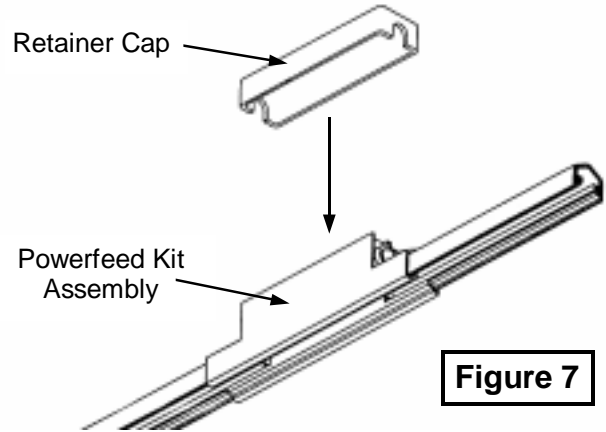

Figure 7

### 2.4.3 End Powerfeed (See Figure 8)

2.4.3.1 For powerfeed located on end, cut back cover 1-5/8" from end of bar. Attach wire to terminal supplied with kit. Place powerfeed clamp halves and terminal on conductor and fasten with hardware supplied. Press on end cover.

2.4.3.2 If necessary, deform legs of conductor outwards slightly to provide a press fit for plastic end cover.

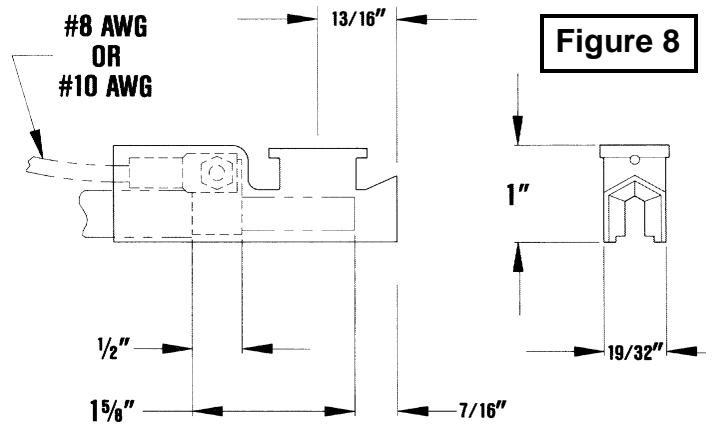

Figure 8

## 2.5 Anchor Clamps

2.5.1 Check installation drawings for anchor clamp locations. If no installation drawings for anchor clamp locations, anchor as shown in Figure 1 on Page 3.

2.5.2 Position one anchor clamp kit on each side of hanger clamp location. Anchor clamp kit to be mounted alternately on two adjacent hanger locations (see Figure 11).

2.5.3 Tighten screws to 35 in. lbs., so that they grab cluster bar. Do not over-tighten.

2.5.4 **Note:** Before tightening anchor clamps, verify that expansion gaps are properly set (see Section 2.6).

2.5.5 On multi-conductor systems, anchor clamps will not fit on adjacent conductors and so must be staggered (see Figure 9).

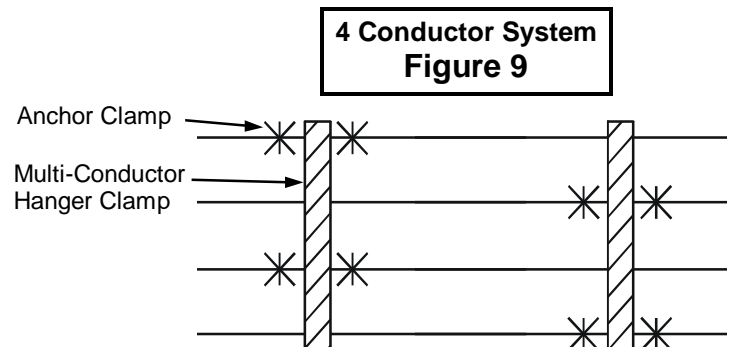

4 Conductor System  
Figure 9

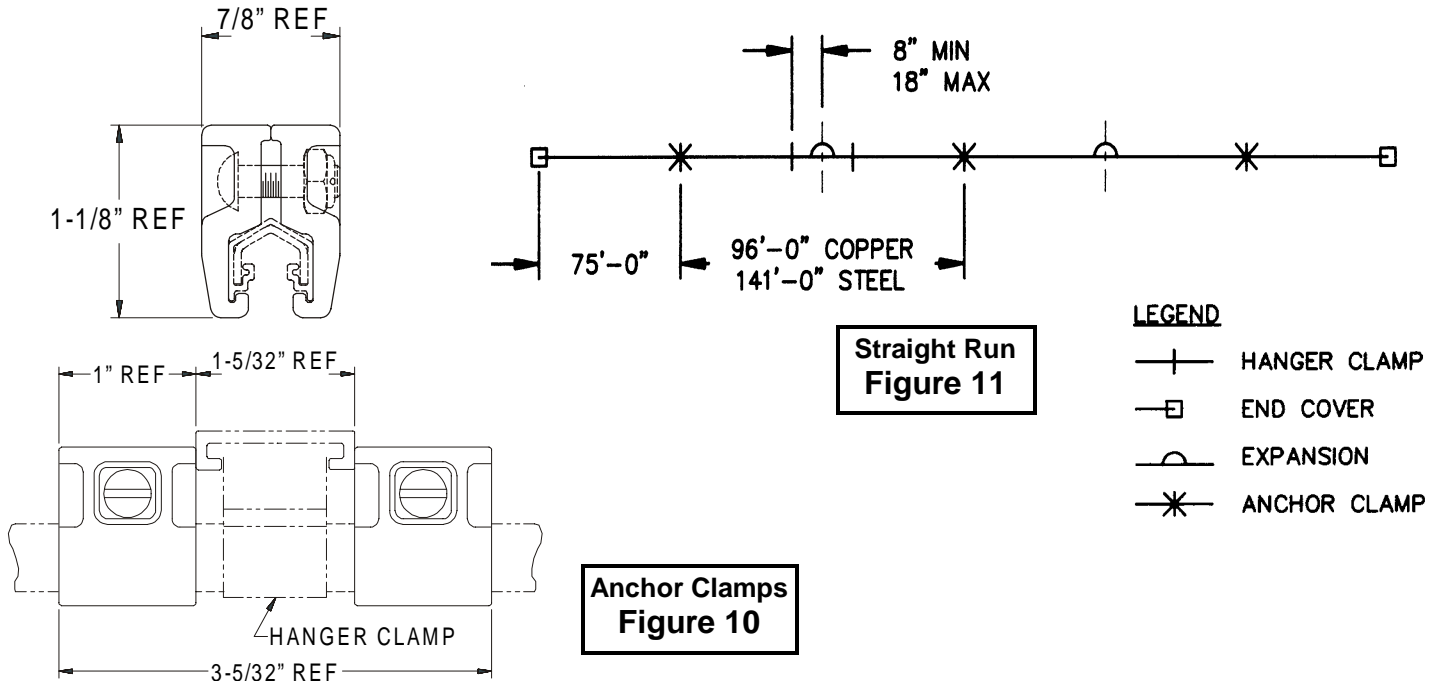

## 2.6 Expansion Section

2.6.1 **Note:** Location of expansion sections is important! If no installation drawings for location of expansion sections, install as shown in Figure 11 above. Mount expansion sections halfway between anchor points. See installation drawing for placement. **Special Note:** Expansion sections will not operate on curves.

2.6.2 Maximum distance between expansions are as follows:

Copper	96 ft.
Galvanized Steel	141 ft.

2.6.3 Attach expansion section in same manner as conductor bar. Set gaps according to the following chart:

Bar Temperature (Degrees F)	Gap Setting (in.) (Between ends of conductors.)
110	3.25
100	3.36
90	3.47
80	3.58
70	3.68
60	3.80
50	3.91
40	4.02
30	4.13

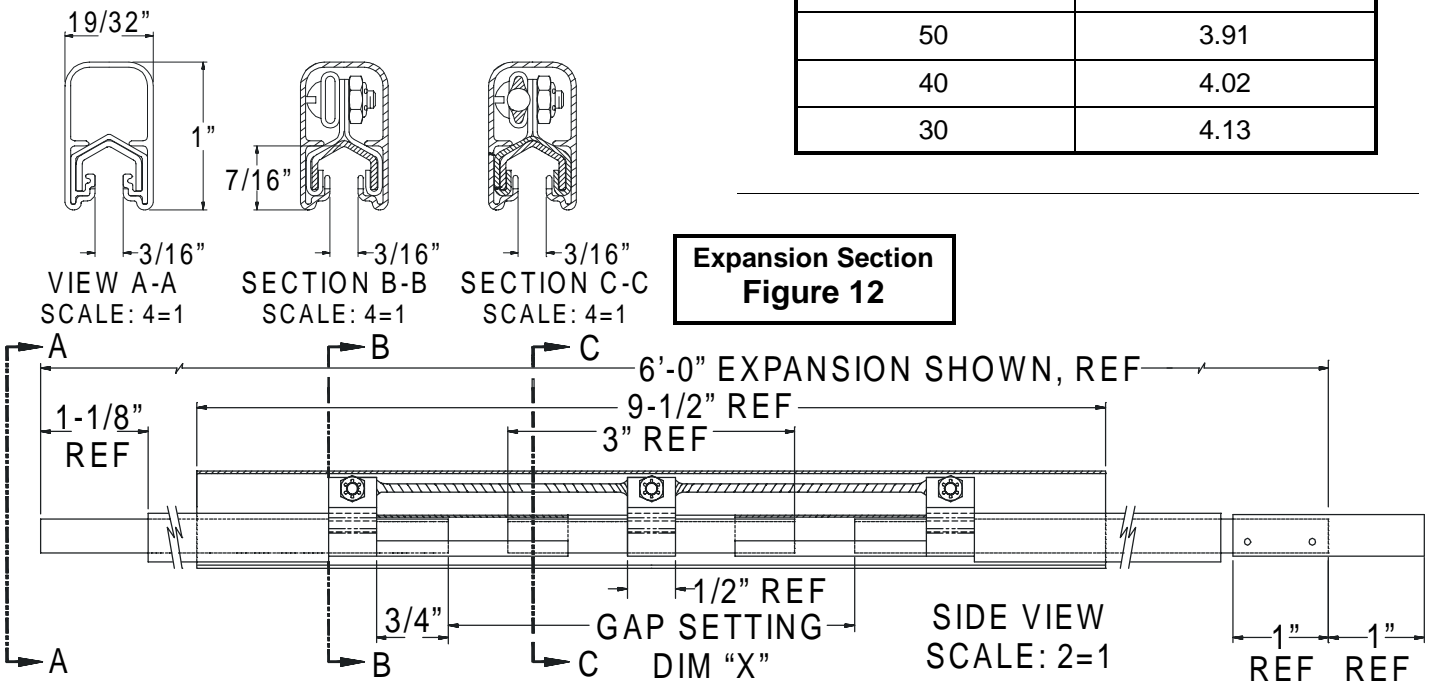

## 2.7 End Cap (See Figure 13)

2.7.1 If conductor bar has crimp splice, cut off splice and install end cap.

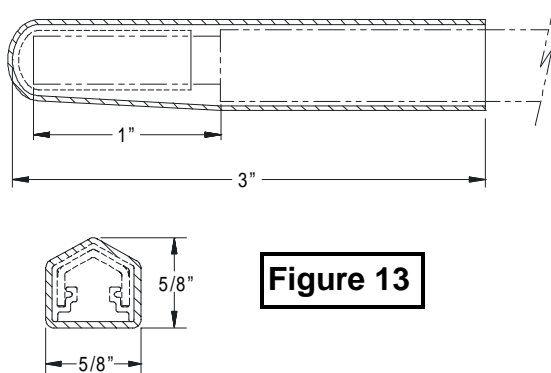
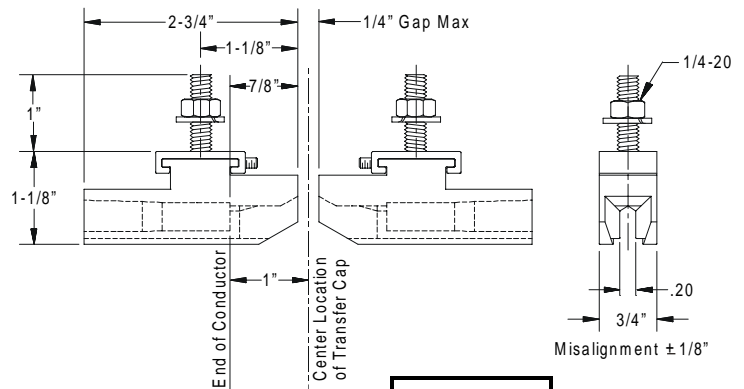

**Figure 13**

## 2.8 Transfer Cap (See Figure 14)

2.8.1 Cut conductor bar 1" shorter than center location of transfer cap. Prepare the end of the cluster bar and cover in the same manner as one having a splice installation.

2.8.2 Press transfer cap on cluster bar.



**Figure 14**

## 2.9 Collector Mounting Dimensions (See Page 9)

# 3.0 MAINTENANCE

### 3.1 Warning: Be sure power is turned off.

3.2 Maintenance of conductor system is dependent on atmospheric conditions and frequency of use. The frequency of inspection depends on the age of the system. A new system should be checked after one month and again the following month until a pattern of maintenance is established. For example, a class "C" (moderate service) crane handling 50% of rated capacity with 5 to 10 lifts per hour should require maintenance approximately every six months after the first year of service.

### 3.3 Collectors

3.3.1 Any accumulation of dirt or dust should be removed from the collector.

3.3.2 Replace worn collector shoes.

3.3.3 Check spring tension to provide proper pressure on every collector shoe. Replace weak springs.

3.3.4 **Note: Check for free mechanical action of collector to conductor. Clean and lubricate where necessary.**

3.3.5 Realign collectors vertically and horizontally to the

collector mount and to the conductor. Ensure that pigtail cable does not cause misalignment of shoe on conductor.

### 3.4 Conductors

3.4.1 Wipe contact surface and cover clean of grease, dust and dirt. Sufficient accumulation may cause a ground.

3.4.2 **Check straightness and alignment of conductor and relieving hanger clamps to permit sliding action for free expansion of conductor.**

3.4.3 Check plastic cover for wear and misalignment at joints. Replace unduly worn sections. Check vertical and horizontal alignment of conductor.

3.4.4 Check at switches, transfer points, expansion gaps, etc., for wear. Replace unduly worn parts. Tighten loose bolts.

3.4.5 Where bar has been bent or joints broken by ladders, ropes, etc., or where bar has been pitted by arcing collector, replace by cutting out with hacksaw and clamping new section in place.

## 2.9 Collector Mounting Dimensions

**1/2" Square Bar Mount Figure 15**

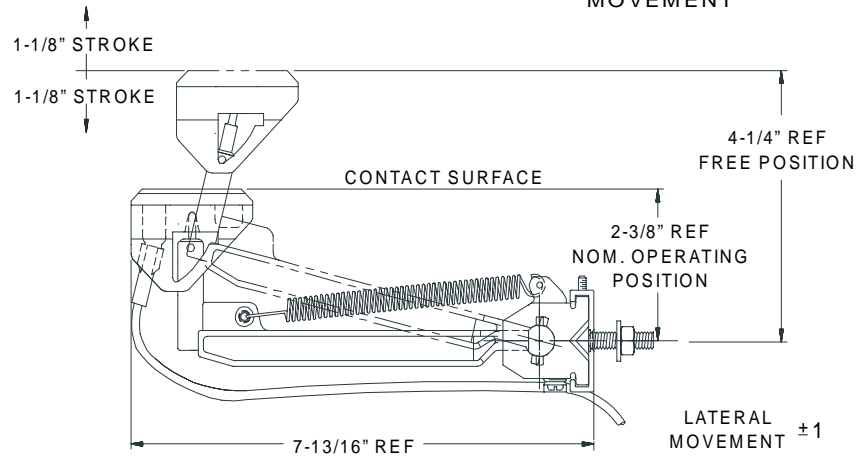
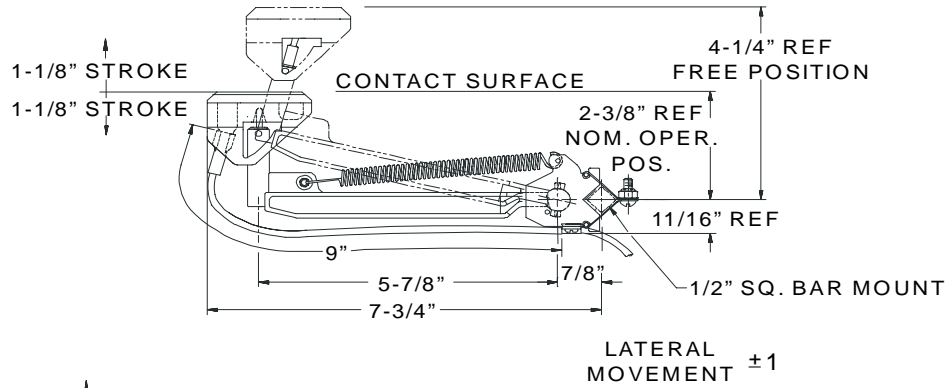

**Channel Mount Figure 18**

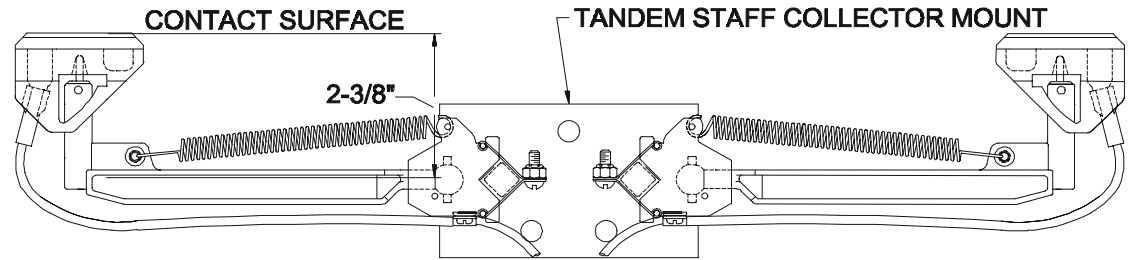

**Tandem Staff Mount Figure 16**

**Staff Collector Mount Figure 17**

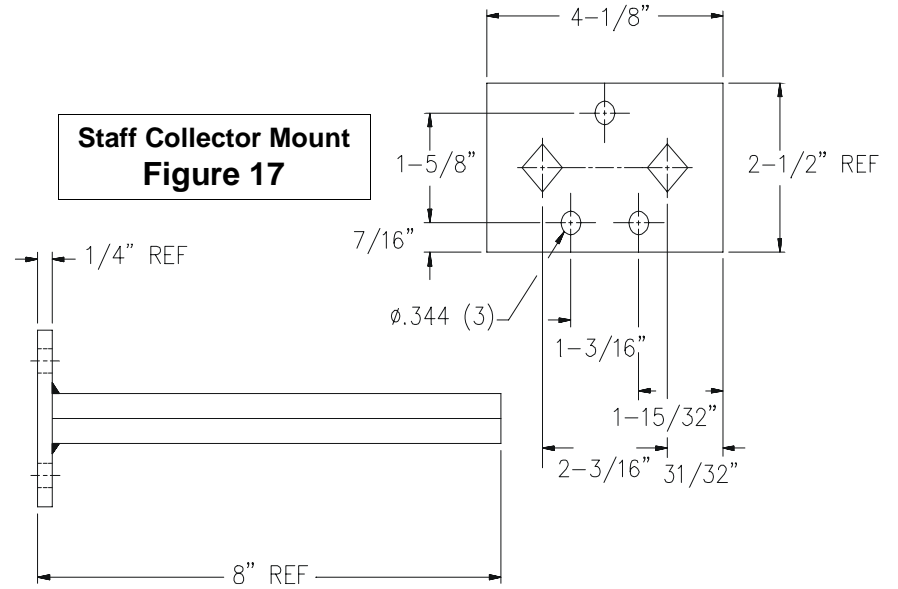

**Tandem Channel Mount Figure 19**

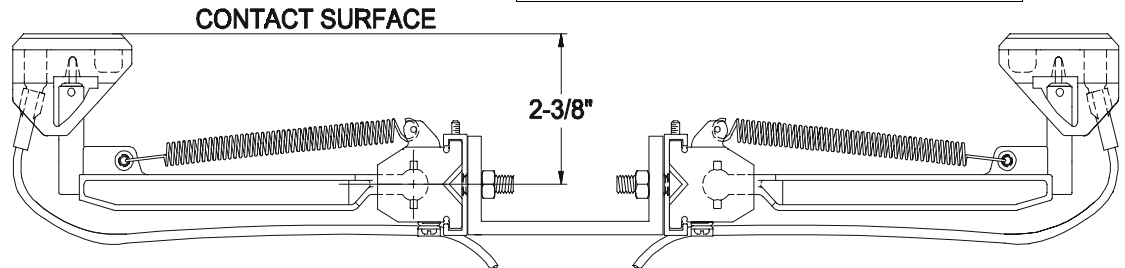

## 4.0 TROUBLESHOOTING

4.1 Properly installed and normally inspected rigid conductor systems very seldom require extensive maintenance. When properly installed, shoe inspection and replacement is usually all that is necessary.

<b>Cluster Bar Conductor Troubleshooting</b>		
<b>Problem</b>	<b>Probable Cause</b>	<b>Solution</b>
Burned joints or burned cover at joints.	Loose joint, excess vibration, or over tightened hanger clamps.	Tighten joint, check hanger clamps, & replace joint cover.
Distorted cover.	Too high ambient temperature, under-rated bar.	Check total current draw under worst conditions.
Pitted or burned conductor.	Improper shoe pressure or worn out shoe.	Check collector mounting and spring pressure. Check for worn out shoe. If the above are corrected & condition persists, install tandem collectors.

<b>Cluster Bar Collector Troubleshooting</b>		
<b>Problem</b>	<b>Probable Cause</b>	<b>Solution</b>
Shoes wearing unevenly	Collector not mounted directly under conductor. Square bar is rotated out of square.	Remount or adjust collector.
	Lead wire not slacked.	Loosen lead wire.
	Collector movement too tight.	Free collector movement & lubricate.
Shoes pitted or burned	Insufficient shoe pressure. Excessive bouncing or hand-pulled trolley not stable.	Check shoe pressure and mounting distance. Excessive bouncing can be reduced with tandem collectors. Install guide rollers on hand pulled trolleys. Also see: Pitted or burned conductor.
De-tracking.	Distorted cover or joint cover.	Check condition, replace as necessary.
	Misalignment at switches or crossovers.	Re-align and re-anchor. Check switch movement.
	Improperly installed.	Correct misalignment.
	Hanger clamp too tight making bar "snake" to where collectors interfere with each other.	Loosen hangers so bar will slide. Tighten one hanger in center or between each expansion section.

# 5.0 TYPICAL INSTALLATIONS

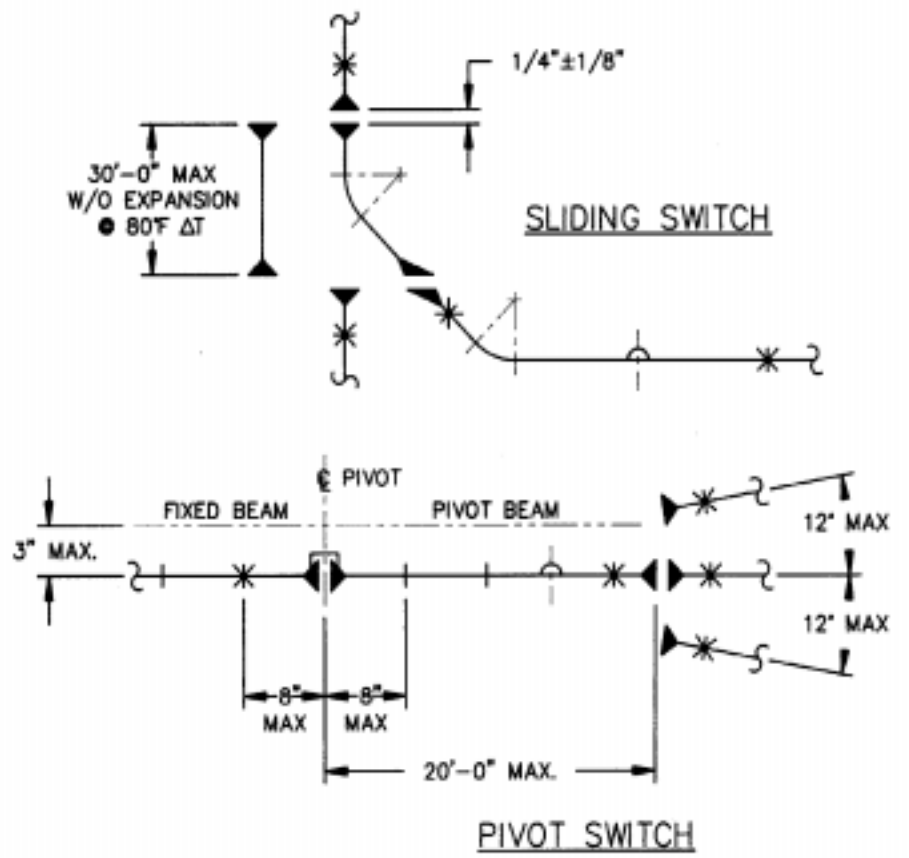
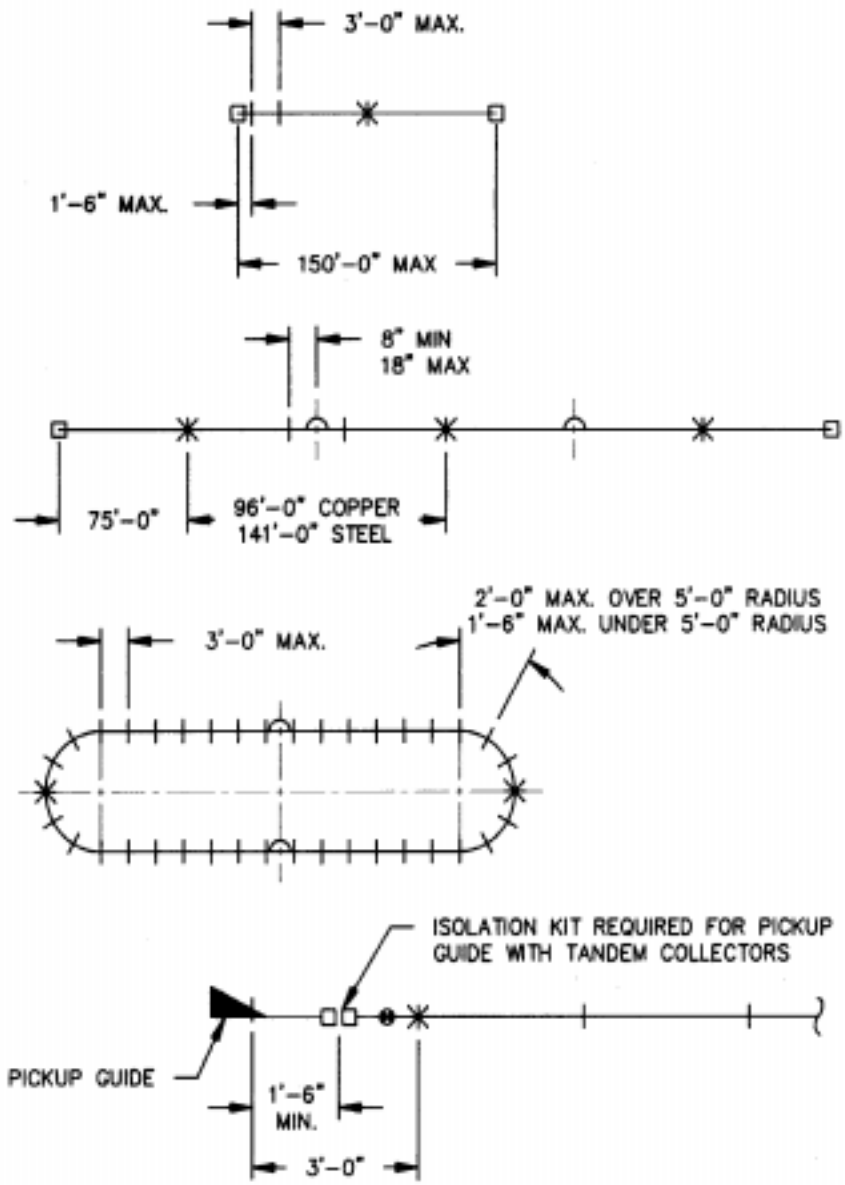

### LEGEND

- |     |               |    |                        |
|-----|---------------|----|------------------------|
| — — | HANGER CLAMP  | ▶  | TRANSFER CAP, STRAIGHT |
| —E— | END COVER     | ▶  | TRANSFER CAP, ANGLE    |
| —○— | EXPANSION     | ◀▶ | TRANSFER CAP, SWIVEL   |
| —*— | ANCHOR CLAMP  | ▲  | PICKUP GUIDE           |
| —□— | ISOLATION KIT | ●  | POWERFEED              |

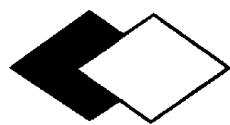

**INSUL 8**  
**CONDUCTIVE DIVISION**



Ⓞ DELACHAUX GROUP

***YOUR SINGLE SOURCE FOR MOBILE ELECTRIFICATION SYSTEMS***

---

Conductor Bar

Cable Festoon Systems

Cable & Hose Reels

Motor Driven Reels

Slip Rings

---

*Please visit our website at:*  
[www.insul-8.com](http://www.insul-8.com)

---

**CANADA**

175 Boulevard J.F. Kennedy  
St. Jerome, Quebec J7Y 4B5

Phone: (514) 565-9900  
Toll Free: (800) 667-2487  
Fax: (514) 432-6985

**USA**

10102 F Street  
Omaha, NE 68127

Phone: (402) 339-9300  
Toll Free: (800) 521-4888  
Fax: (402) 339-9627

**AUSTRALIA**

14 England Street  
Dandenong, Victoria 3175

Phone: (3) 9706 88 44  
Fax: (3) 794 92 98